

TRACK AND COUNTER BALANCE ASSEMBLIES WERE OMITTED FROM ALL DETAILS ON THIS PAGE FOR CLARITY. SEE SHEET 3 FOR TRACK AND COUNTER BALANCE DETAILS

DOORS TESTED PER ANSI/DASMA 108 FOR STATIC AIR PRESSURE

MAXIMUM DOOR WIDTH	DESIGN LOAD
10' - 2"	+ 34.0 - 38.5

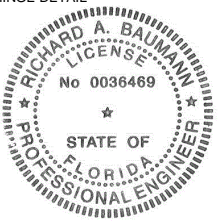

Richard A. Baumann
F.P.E #36469
T.P.E # 85227
698 Timber Creek Road
Dixon Illinois 61021

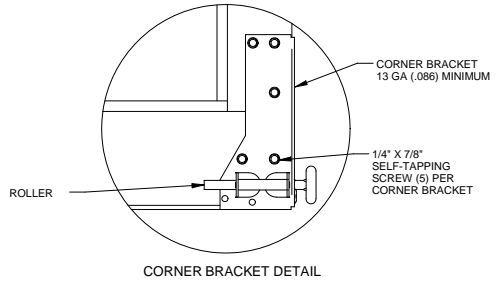

SCALE: NONE		DRAWN BY: G.WEBEKIND		TITLE: SPEC, WIND LOAD ALUMAVIEW AND STYLEVIEW	
CHECKED BY: GW		DATE: 07/03/12		GARAGE DOORS	
DATE: 07/03/12		ECLN NO. 6338.01		NO. P-2412	
REV	DESCRIPTION	ECLN NO.	DATE	ECLN NO.	REV
A	RELEASED FOR PRODUCTION	6338.01	07/03/12	6338.01	1 OF 4

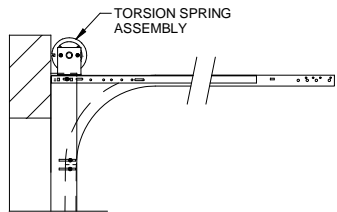

NORMAL HEADROOM TRACK
2" TRACK ANGLE MOUNT SHOWN
2" TRACK BRACKET MOUNT AVAILABLE
3" TRACK ANGLE MOUNT AVAILABLE

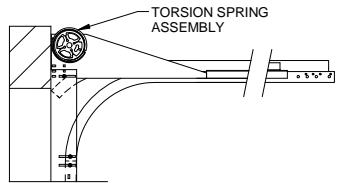

FRONT MOUNT LOW HEADROOM TRACK
2" TRACK ANGLE MOUNT SHOWN
2" TRACK BRACKET MOUNT AVAILABLE
3" TRACK ANGLE MOUNT AVAILABLE

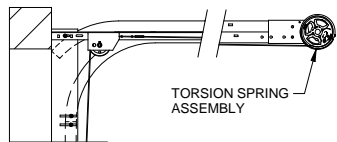

REAR MOUNT LOW HEADROOM TRACK
2" TRACK ANGLE MOUNT SHOWN
2" TRACK BRACKET MOUNT AVAILABLE
3" TRACK ANGLE MOUNT AVAILABLE

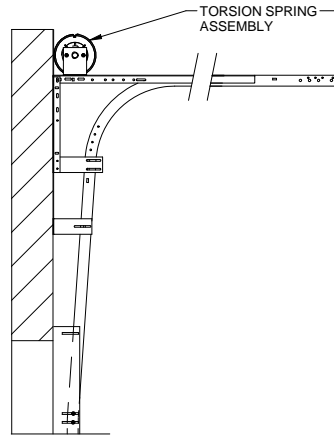

LIFT CLEARANCE TRACK
2" TRACK ANGLE MOUNT SHOWN
2" TRACK BRACKET MOUNT AVAILABLE
3" TRACK ANGLE MOUNT AVAILABLE

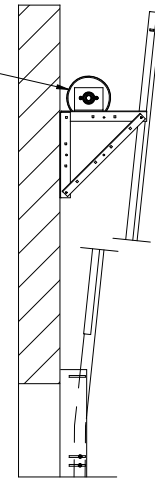

VERTICAL LIFT TRACK
2" TRACK ANGLE MOUNT SHOWN
2" TRACK BRACKET MOUNT AVAILABLE
3" TRACK ANGLE MOUNT AVAILABLE

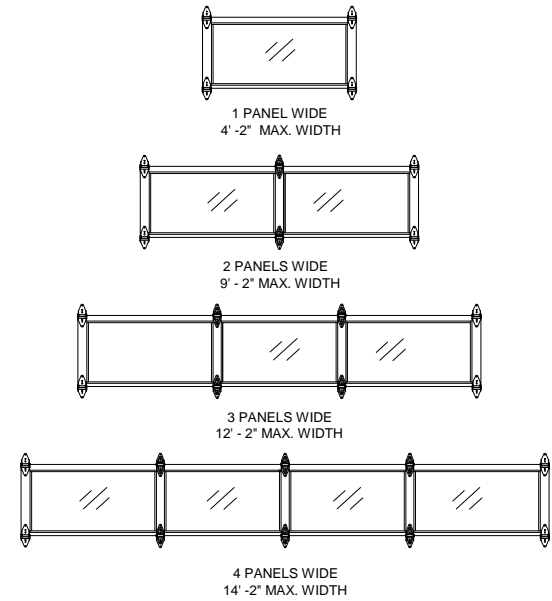

CENTER STILE AND PANEL LAYOUT
INTERIOR VIEW
INTERMEDIATE SECTION SHOWN

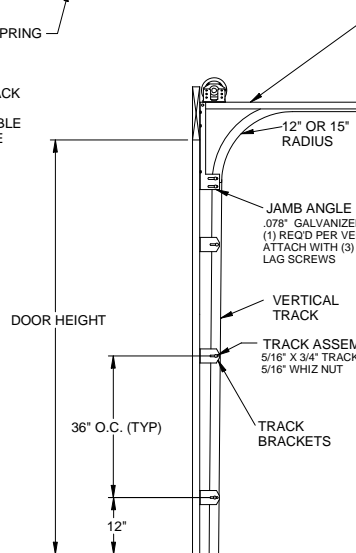
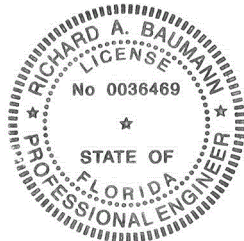

TYPICAL TRACK INSTALLATION
BRACKET MOUNT
WOOD JAMBS

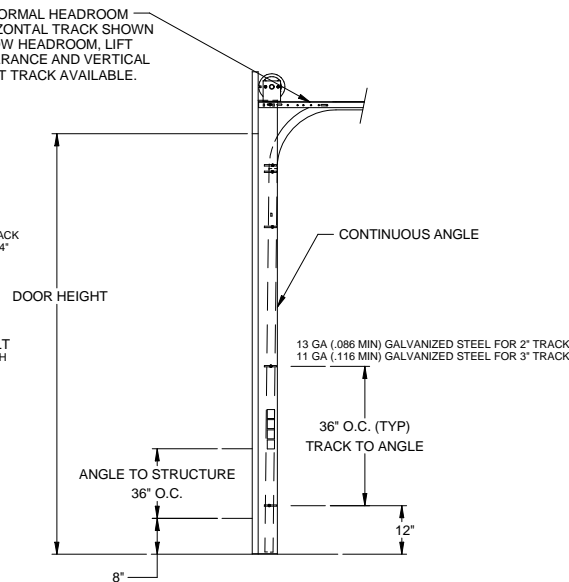

TYPICAL TRACK INSTALLATION
ANGLE MOUNT
WOOD, STEEL OR MASONRY
JAMBS

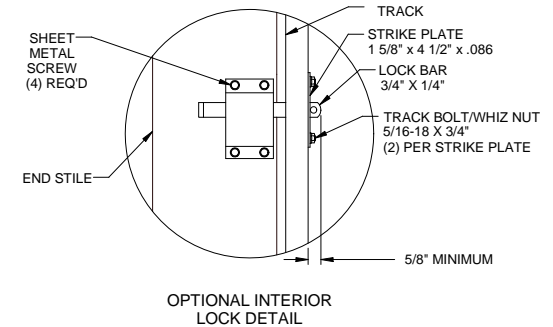

OPTIONAL INTERIOR
LOCK DETAIL

Richard A. Baumann
F.P.E #36469
T.P.E # 85227
698 Timber Creek Road
Dixon Illinois 61021

SCALE: NONE	DRIVEN BY: G.WEBEKIND		TITLE: SPEC, WIND LOAD ALUMAVIEW AND STYLEVIEW			
CHECKED BY: GW	DATE: 07/03/12		NO. P-2412			
REV	DESCRIPTION	ECL NO.	DATE	ECL NO. 6338 01	SHEET 2 OF 4	REV A

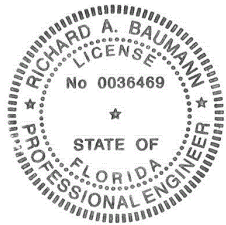
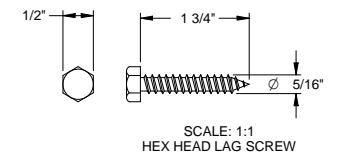
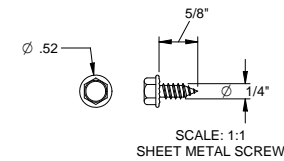
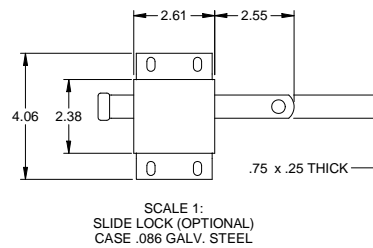
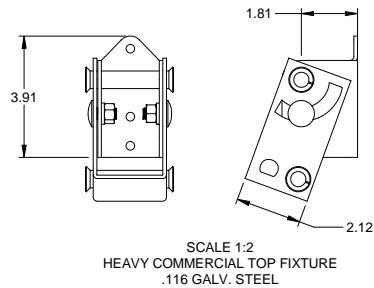
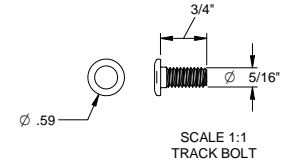
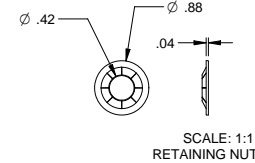
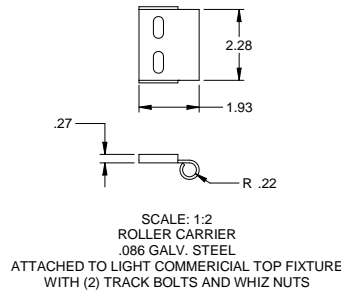
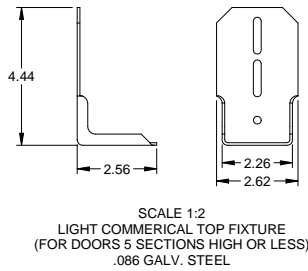
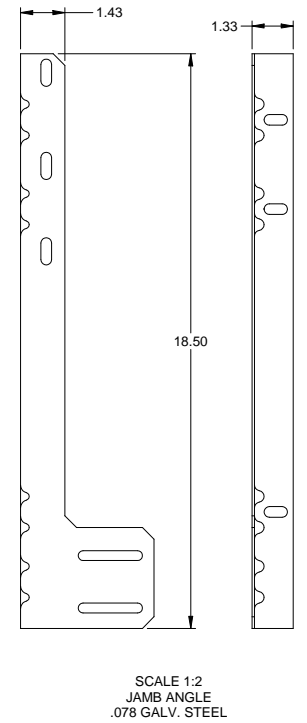
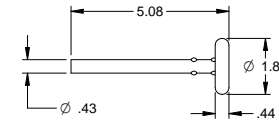
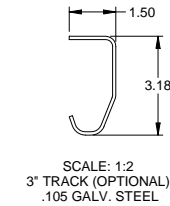
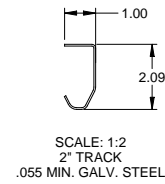
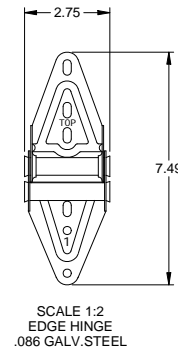
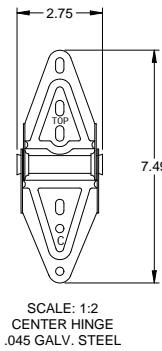
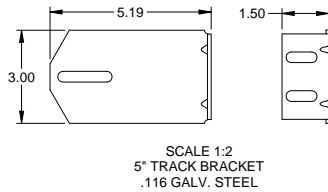
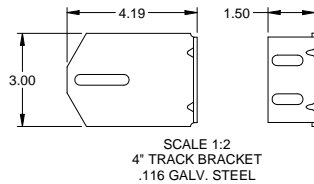
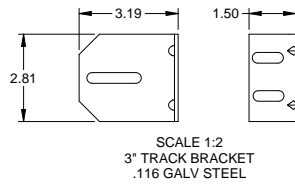
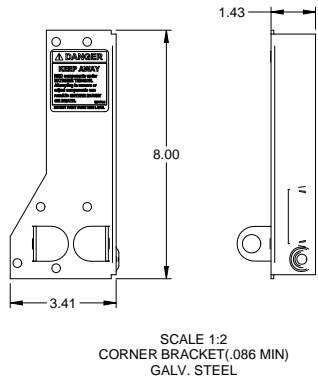

Richard A. Baumann
F.P.E #36469
T.P.E # 85227
698 Timber Creek Road
Dixon Illinois 61021

SCALE: NONE		DRAWN BY: G.WEBEKIND		TITLE: SPEC, WIND LOAD ALUMAVIEW AND STYLEVIEW	
CHECKED BY: GW		DATE: 07/03/12		GARAGE DOORS	
ECON. NO.:		DATE:		801 HILDAET RIVER ROAD DIXON, IL 61021	
ECON. NO. 6338 01		ECON. NO.:		NO. P-2412	
DESCRIPTION:		DATE:		SHEET 3 OF 4	
REV:		DATE:		REV A	

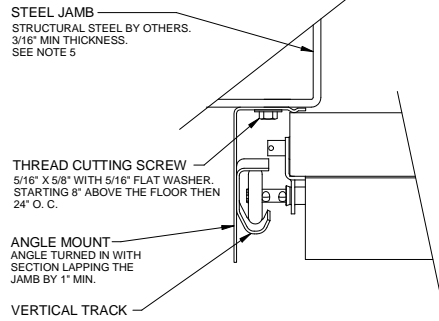

TRACK ASSEMBLY ATTACHMENT TO STEEL JAMB
2\"/>

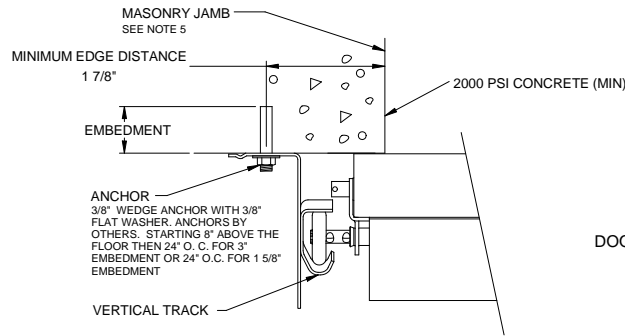

TRACK ASSEMBLY ATTACHMENT TO MASONRY JAMB
2\"/>

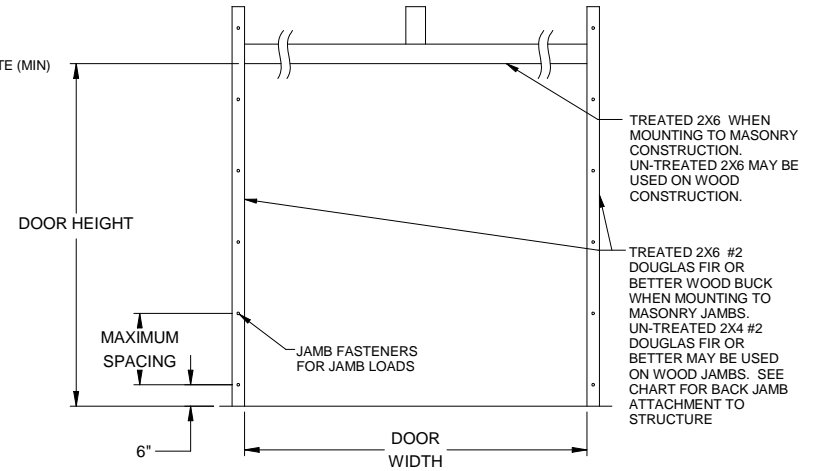

JAMB ATTACHMENT

1/4" ITW BUILDEX TAPCON				
JAMB TYPE	EMBEDMENT	EDGE DISTANCE	ALLOWABLE TENSION LOAD	MAXIMUM ON CENTER SPACING
2000 PSI CONCRETE	1-3/4"	2-1/2"	505	24"
3000 PSI CONCRETE	1-3/4"	2-1/2"	550	24"
5/16" ITW BUILDEX TAPCON				
3000 PSI CONCRETE	1-3/4"	2 3/16"	563	24"
POWER ANCHOR - 3/8" WEDGE ANCHOR				
2000 PSI CONCRETE	1-5/8"	1-7/8"	360	24"
	3"	1-7/8"	768	24"
5/16" LAG SCREW				
SPRUCE, PINE, FIR (G = .42)	1-1/2"	1-3/4"	307	21-1/4"
DOUGLAS FIR (G = .46)	1-1/2"	1-3/4"	352	24"
SOUTHERN YELLOW PINE (G = .55)	1-1/2"	1-3/4"	460	24"
3/8" LAG SCREW				
SPRUCE, PINE, FIR (G = .42)	1-1/2"	1-3/4"	352	24"
DOUGLAS FIR (G = .46)	1-1/2"	1-3/4"	403	24"
SOUTHERN YELLOW PINE (G = .55)	1-1/2"	1-3/4"	528	24"
5/16 X 5/8 THREAD CUTTING SCREW				
STEEL A 36	3/16"	1/2"	1048	24"

JAMB ATTACHMENT NOTES

- 1/4" DIAMETER ANCHORS REQUIRE 5/8" MIN. O.D. STEEL WASHER.
- 5/16" AND 3/8" DIAMETER FASTENERS REQUIRE 7/8" MIN O.D. STEEL WASHER.
- MAXIMUM POSITIVE LOAD PER JAMB = (10'-2" X 34.0 PSF) / 2 = 173 LBS PER FOOT
- MAXIMUM NEGATIVE LOAD PER JAMB = (10'-2" X 38.5 PSF) / 2 = 196 LBS PER FOOT.
- DESIGN OF THE SUPPORTING STRUCTURE SHALL BE THE SOLE RESPONSIBILITY OF THE BUILDING DESIGNER AND SHALL BE DESIGNED FOR THE JAMB LOADS LISTED IN NOTES 3 AND 4.
- ALTERNATE JAMB ATTACHMENTS MAY BE USED IF APPROVED BY A REGISTERED PROFESSIONAL ENGINEER.

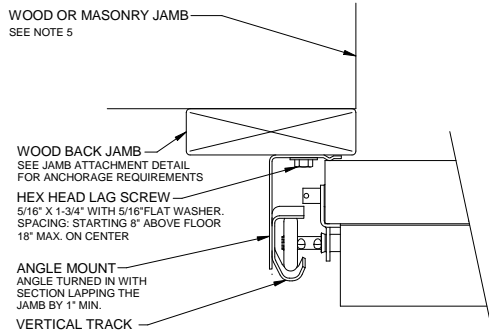

TRACK ASSEMBLY ATTACHMENT TO WOOD BACK JAMB
2\"/>

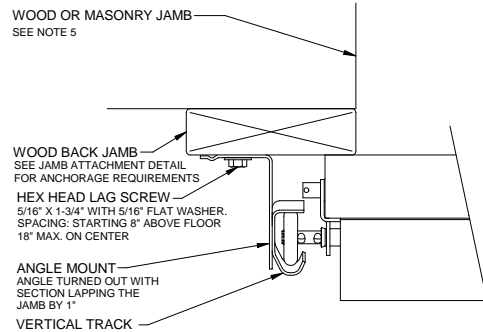

TRACK ASSEMBLY ATTACHMENT TO WOOD BACK JAMB
2\"/>

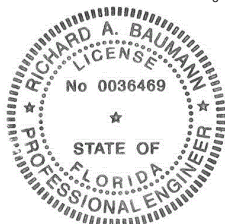

Richard A. Baumann
F.P.E #36469
T.P.E # 85227
698 Timber Creek Road
Dixon Illinois 61021

SCALE: NONE		TITLE: SPEC, WIND LOAD ALUMAVIEW AND STYLEVIEW		
DRAWN BY: G.WEBEKIND		NO. P-2412		
CHECKED BY: GW			SHEET 4 OF 4	
DATE: 07/03/12		REV A		
REV	DESCRIPTION	ECON. NO.	DATE	ECON. NO. 6338 01